

SEKN

Compatible Workpiece Materials



Steel



Stainless Steel



Heat-Resistant Steel

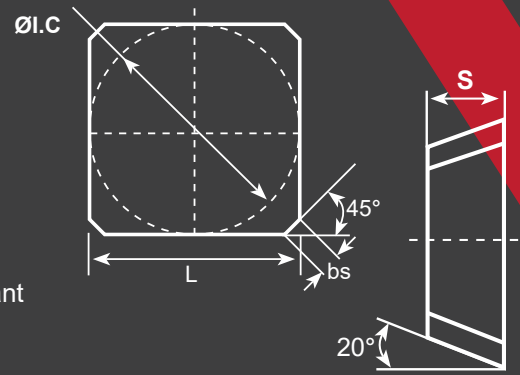

SKU#	ANSI#	ISO#	L	ØI.C	S	bs
424-1505	SEKN 42 AFTN	SEKN1203AFTN	0.5	0.5	0.125	0.071

	START SPEED	START FEED
P	Vc: 800sfm (600-1100)	fz: 0.008in/z (0.004-0.012)
M	Vc: 450sfm (300-800)	fz: 0.008in/z (0.004-0.012)

Material	Coated grade													Cermet		Cemented Carbide					
	YBC302	YBM251	YBM253	YBM351	YBD152	YBD252	YBG102	YBG105	YBG202	YBG205	YB9320	YBG302	YBG152	YBG252	YNG151	YNG151C	YC30S	YD051	YD101	YD201	
P Steel	+	+	+	-					+	+	+	+		+	+	+	-				
M Stainless Steel	+	+	+	-					+	+	+	+		+	+	+	-				
K Cast Iron					+	-	+						+	+				+			-
N Ferrite Materials																			+		-
S Heat-resistant steel							+	+	+												
SKU#																					
424-1505									●												

+ Good Working Conditions

○ General Working Conditions

- Adverse Working Conditions